

Fig.1 The UWI module.

### APPLICATION

Timing circuit coupling a voltageless pulse transmitter with a controller.

### DESCRIPTION

The UWI is used in pulse measurement systems to produce a voltage signal (12V) with a length of 1,3 to 3,5 seconds. Is released by trailing edge, which means that opening input terminals (11, 12) generates an output pulse. The minimum close time of terminals is 1,6ms (310Hz for duty cycle 50%). The LED diode indicates an output state.

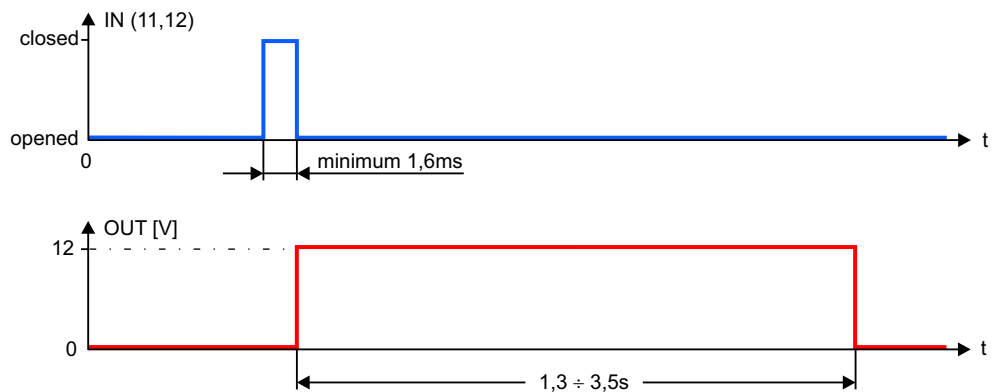
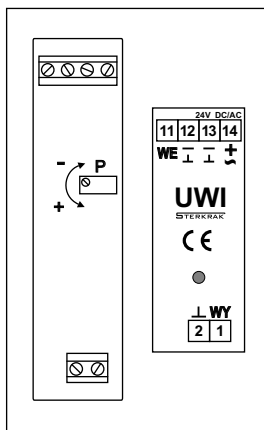

Fig.2 Regulation method and timing diagram.

P - the multiturn potentiometer

One full turn of the potentiometer axle:

- to the right ("-") direction) shorten the pulse duration to about 100 ms,
- to the left ("+" direction) lengthen the pulse duration to about 100 ms.

**REMARK:** The length of pulse and output voltage can be set individually according to the specification.

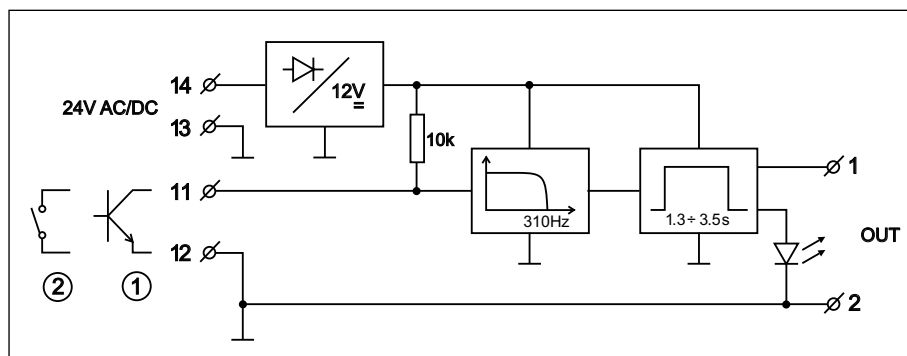

- ① Transistor transmitter
- ② Reed relay transmitter

Fig.3 Connections of the UWI.

## TECHNICAL DATA

Power supply	24 V AC/DC $\pm 10\%$
Current consumption for $R_L = 10k\Omega$	15 mA for 24 V AC 9 mA for 24 V DC
Input pulse minimal duration	1,6 ms
Input current for $R_{IN} = 0\Omega$	1,2 mA
Max. input resistance	4,7 k $\Omega$
Output signal	12V DC, max 10 mA
Output pulse duration	1,3 to 3,5 s
Output pulse factory setting	1,5 s $\pm 1\%$
Protection class of the case	IP-40
Protection class of terminals	IP-20
Ambient temperature range	-10...+55°C
Diameter of terminals	2,5 mm <sup>2</sup>
Protections	against reverse polarisation
Mounting	DIN-35 or DIN-32 rail
Dimensions (L x W x H)	96mm x 27mm x 42mm
Weight	50 g

February 2005, revised: June 2008